

400 Series

404D-15

Compact Agricultural, Lawn and Garden Power

26.5 kW / 35.5 bhp @ 3000 rpm

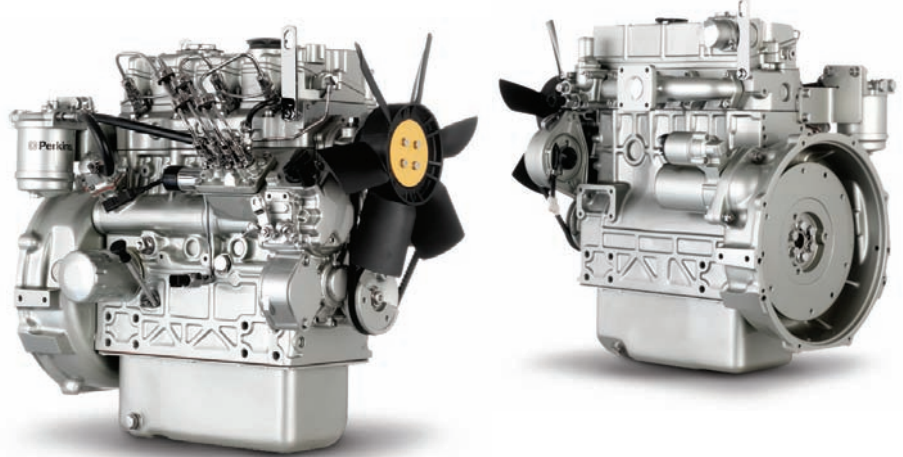

The Perkins 400D range has been developed in consultation with our marketplace. This 1.5 litre, 4 cylinder engine complements the exciting 400 Series product line-up, offering customers a choice of compact, lightweight power units whilst maintaining all the customer benefits they can experience from other products in the range.

The 400 Series engine family continues to set new standards in the compact engine market. Developed alongside customers to fulfil their needs in the construction, materials handling, agricultural/turf, geset and compressor markets, it is another class leading diesel range from Perkins.

Built to the most demanding standards, the 400D engines meet all the requirements of the off-highway emissions legislation for Stage IIIB, Tier 4 Interim and MLIT Step 4 (see 'Perkins Emissions Statement' on page 2).

Long 500 hour service intervals, a two-year standard warranty, low noise and harshness, and a wide range of options make the 400 Series range the complete solution for compact power needs.

The 404D-15 is a 4 cylinder 1.5 litre unit delivering smooth, impressive performance, with low operating costs in a small, efficient package ideal for the agricultural, lawn and garden sectors.

Ultra-compact power

- Up to 26.5 kW from an engine envelope of 0.14 m³.
- Easy installation.

Clean and quiet

- Noise levels have been kept to a minimum.
- Subjective harshness has been carefully controlled making the engine sound even quieter.

Durable power

- Product design and process improvements enhance both engine reliability and durability.
- A new governor, valve seat inserts, and new compliance testing deliver reliability of 6,000 hours.
- A standard 2-year warranty demonstrates our confidence in durability and reliability.

Low operating costs

- Approved for operation on biodiesel* concentrations of up to 20%.
- Oil and filter changes are 500 hours, dependent on load factor.
- Engine durability and reliability, the warranty offering, and ease of installation combine to drive down the cost of ownership.

Product support

- Through an experienced global network of distributors and dealers, fully trained engine experts deliver total service support around the clock, 365 days a year. They have a comprehensive suite of web based tools at their fingertips, covering technical information, parts identification and ordering systems, all dedicated to maximising the productivity of your engine.
- Perkins actively pursues product support excellence by insisting our distribution network invest in their territory to provide you with a consistent quality of support across the globe.
- Throughout the entire life of a Perkins engine, we provide access to genuine OE specification parts giving 100% reassurance that you receive the very best in terms of quality for lowest possible cost... wherever your Perkins powered machine is operating in the world.

Performance Data	Gross Power	Speed (rev/min)
Power Output (kW)	26.5	3000
Power Output (bhp)	35.5	3000
Peak Torque (Nm)	94.4	1800
Peak Torque (lbf ft)	69.6	1800

Power output for a run-in engine after 60 hours.
*Subject to conformance with ASTM D6751 and EN14214.

400 Series - 404D-15

Compact Agricultural,
Lawn and Garden Power

26.5 kW / 35.5 bhp @ 3000 rpm

Engine specification

- Cast iron engine block
- Flywheel and flywheel housing
- Fuel injection pump
- Spin on fuel filter
- Glow plug starting aid
- Lub oil sump
- Spin on lub oil filter
- Inlet manifold
- Cast iron exhaust manifold – side outlet
- Coolant pump belt driven
- Starter motor 12 volt
- Alternator 12 volt
- ESOS (Electric shut-off solenoid)
- Lub oil pressure switch
- Coolant temperature switch
- Choice of cooling fans
- SAE A-A PTO
- Cold start capability to -20°C (aided)
- Gradeability 35° continuous

Option groups

A selection of optional items is available to enable you to prepare a specification precisely matched to your needs.

Emissions statement

- Variable Speed: Industrial and IOPU engines: Certified against the requirements of EU Stage IIIB (Directives 97/68/EC, as last amended, and 2005/26/EC, as last amended); and US EPA Tier 4 Interim (40CFR Parts 1039. (NOTE Tier 4 Final will start in 2013 model year for 19-56 kW engines).
- Constant Speed Engines for use in Industrial, IOPU and ElectropaK applications: Certified against the requirements of EU Stage IIIA (Directives 97/68/EC, as last amended, for mobile applications); and US EPA Tier 4 Interim (40 CFR Parts 60 for stationary applications and 40CFR Part 1039 for mobile applications).

Perkins Engines Company Limited

Peterborough PE1 5NA
United Kingdom
Telephone +44 (0)1733 583000
Fax +44 (0)1733 582240
www.perkins.com

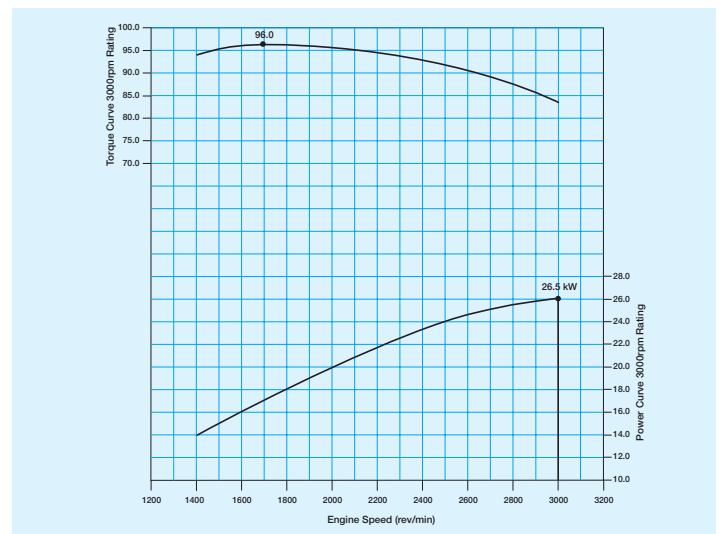
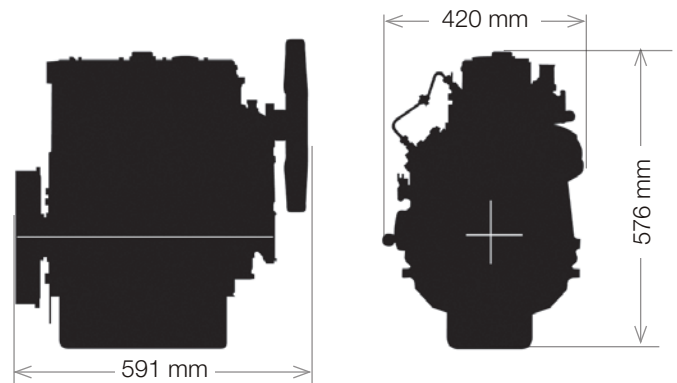

Lower speed ratings may not be read from this curve.

Engine data

Number of cylinders	4 in-line
Bore and stroke	77 x 81 mm
Displacement	1.5 litres
Aspiration	Naturally aspirated
Cycle	4 stroke
Combustion system	Indirect injection
Compression ratio	22.9:1
Rotation	Anti-clockwise viewed on flywheel
Cooling system	Liquid
Total lubrication capacity	5.6 litres
Total coolant capacity	2.4 litres
Dimensions	
Length	591 mm
Width	420 mm
Height	576 mm
Dry weight	106.8 kg

Final weight and dimensions will depend on completed specification.

Distributed by: