

4000 Series

4012TESI

Spark Ignited Gas Engine

600 kWm at 1200 rpm

632 kWm at 1500 rpm



Designed in advance of today's uncompromising demands within the gas power generation industry, the Perkins 4000 Series family of 6, 8, 12 and 16 cylinder spark ignition gas engines offers superior performance, dependability and reliability.

The 4012TESI is a turbocharged and air-to-air water charged cooled 12 cylinder vee-form engine designed for operation on a wide range of gases including natural, landfill and digester gases. The internationally proven durability and reliability, combined with exceptional thermal efficiency and reduced whole life costs, make selection of the Perkins 4000 Series engine as prime mover the obvious choice. The 4000 Series spark ignited gas engine can be supplied to suit customer requirements as a Gas Electro Unit for power generation or Cogen Unit specification for combined heat and power operations.

Economic power

The modern design of the 4000 Series incorporates the latest development and engineering techniques, resulting in excellent durability, economical whole life costs and reliability.

Efficient power

Designed for maximum thermal efficiency, the 4012TESI offers compact, high power to weight ratio, an economical solution to power and heat requirements. High commonality of components with other engines in the 4000 Series family offers reduced stocking and inventory levels.

Reliable power

The high level of product serviceability and ease of maintenance maintain optimum availability.

Total aftersales service, backed by Perkins' worldwide distributor/dealer network.

Engine Speed (rev/min)	Type of Operation	Gross Engine Power	
		kWe	kWm
1200	Continuous Operation Power	576	536
1500	Continuous Operation Power	600	600

The above ratings represent the engine performance capabilities in accordance with ISO 3046 at reference conditions equivalent to those specified in ISO 3046/1. Electrical ratings are based on average alternator efficiency at a unity power factor based on natural gas having a lower calorific value of 34.71 MJ/m³.

Please consult your local Perkins distributor/dealer or Perkins Engines Company Limited for derating calculations for ambient conditions or use of gaseous fuels other than British natural gas.

Rating Definitions

Continuous Operation Power: A 'true' base load rating as defined in ISO 8258 as COP.

All information in this document is substantially correct at time of printing and may be altered subsequently

Publication No. 2187/01/10 Produced in England ©2005 Perkins Engines Company Limited

4000 Series

4012TESI

Standard Gas Engine Specification

Core engine

- High-grade cast iron cylinder block featuring integral crankcase inspection doors
- Wet liners in centrifugally cast iron, plateau honed
- Forged steel crankshaft
- Forged camshaft – carburised hardened
- High grade cast iron individual cylinder heads,
- Aluminium alloy gallery (oil) cooled piston with three-ring pack
- Split cap connecting rods, forged steel with two bolt fixing

Gas/Ignition system

- Adjustable air/fuel mixers with zero pressure regulator
- Metal braided flexible gas connection
- Altronic 8000C Series ignition system and wiring harness
- Individual cylinder ignition coils

Lubrication system

- Gear driven lubricating oil pump, externally mounted
- Spin on type replaceable lubricating oil filters
- Shell and tube oil coolers, jacket water cooled
- Crankcase closed circuit ventilation

Cooling system

- Pressurised fresh water jacket water cooling system
- Centrifugal type, gear driven pumps and thermostatic control †
- Air to water charge coolers, secondary water-cooled
- Secondary water pump, centrifugal type, gear driven †
- Charge cooler water thermostat, loose supply †

Air intake system

- Paper element air filters with restriction indicators
- Twin exhaust gas driven turbochargers

Exhaust system

- Cast iron, jacket water-cooled exhaust manifolds
- Twin vertical exhaust outlets †

Governing system

- Electronic governing system, conforming to ISO 8528 G2

Electrical system

- 24 volt electric starter motors and charging alternator †

Drive system

- Flywheel housing SAE 00 and flywheel SAE J620 Size 18
- Viscous type torsional vibration damper(s)

Engine protection system

- 24 volt high coolant temperature and low oil pressure switches
- Overspeed switch and probe
- Emergency stop button – grounding ignition system
- High manifold pressure switch

Engine mountings

- Engine supports: front and rear feet mounted off the crankcase

Painting

- Commercial primer finish

Packing/Preservation

- All engines are preserved after test running, shrink wrapped and suitable for containerised shipment

† Not supplied on Cogen Unit.

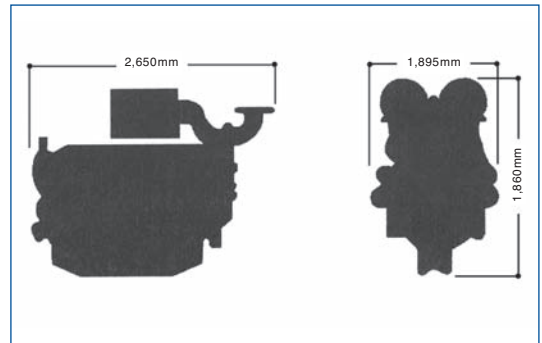

General Data

Number of cylinders	12
Cylinder arrangement	600 Vee
Cycle	4-stroke
Induction system	Turbocharged, charge cooled
Combustion system	Spark ignition
Cooling system	Water-cooled
Bore and stroke	160 x 190mm
Displacement	45.84 litres
Compression ratio	9.5:1 low compression (LC) 11.5:1 high compression (HC)
Direction of rotation	Anti-clockwise, viewed on flywheel
Total lubrication oil capacity	177.6 litres
Coolant capacity	73 litres
Length	2,650 mm
Width	1,895 mm
Height	1,860 mm
Total weight (dry)	4680 kg

Final weight and dimensions will depend on completed specification

Fuel Consumption Targets		
Engine Speed	1200 rev/min	1500 rev/min
4012TESI 200LC		
100% of COP Rating	2.75	2.75
75% of COP Rating	2.87	2.92
4012TESI 140LC*		
100% of COP Rating	2.81	2.88
75% of COP Rating	2.93	3.00
4012TESI 140HC*		
100% of COP Rating	N/A	2.73
75% of COP Rating	N/A	2.80
4012TESI 90HC#		
100% of COP Rating	2.79	2.77
75% of COP rating	2.95	2.90

Fuel consumption figures are for TA Luft compliant engines at ISO 8528/1.
* Cogen specification engine.



Perkins Engines Company Limited

Peterborough PE1 5NA
United Kingdom
Telephone +44 (0)1733 583000
Fax +44 (0)1733 582240
www.perkins.com

Distributed by