

1200 Series

1204E-E44TA/TTA IOPU

EU Stage IIIB, EPA Tier 4 Interim and MLIT Step 4
74.5-129.4 kW /100-173.5 hp

Building on its already strong EU Stage IIIB and EPA Tier 4 industrial range, Perkins is pleased to announce the natural expansion of the 1200 Series to include the new Industrial Open Power Units (IOPUs).

The four cylinder IOPUs are an industry leader in flexibility, offering a wide choice of options to the customer.

The whole engine has been built around the demands of our customers and as such offers a great package with a simple integration design.

The 1204E-E44TA and 1204E-E44TTA IOPUs are turbocharged and series turbocharged respectively. They are air-to-air charge cooled, 4.4 litre, 4 cylinder units capable of producing 74.5 - 129.4 kW (100 - 173.5 hp). These engines provide extra power density and faster response in a compact package - allowing customers to downsize from a six cylinder engine whilst maintaining power.

The IOPUs are designed to be productive and have a new range of power ratings to ensure the customer maximizes their profitability.

Perkins have developed a reputation for designing and building reliable and durable engines suitable for the most demanding applications.

Engine Data

| | |
|--|-------------------------------------|
| Number of cylinders | 4 vertical in-line |
| Bore and stroke | 105 mm x 127 mm (4.13 in x 5 in) |
| Displacement | 4.4 litres (268.5 in ³) |
| Aspiration 1204E-E44TA..... | Turbocharged aftercooled |
| Aspiration 1204E-E44TTA..... | Series turbocharged aftercooled |
| Cycle | 4 stroke |
| Combustion system | Direct injection |
| Compression ratio | 16.5:1 |
| Rotation..... | Anti-clockwise, viewed on flywheel |
| Total lubricating capacity..... | 5.2-13.5 litres (1.37-3.57 US gal) |
| Cooling system | Liquid |
| Total coolant capacity | 10.8 litres (2.85 US gal) |
| Dimensions TA | |
| Length | 1433 mm (56.4 in) |
| Width | 820 mm (32.3 in) |
| Height (incl aftertreatment) | 1126 mm 44.3 in |
| | 1150 mm 45.3in (>82 kW) |
| Dry weight | 650 kg (1433 lbs) |
| Dimensions TTA | |
| Length | 1433 mm (56.4 in) |
| Width | 795 mm (31.3 in) |
| Height (incl aftertreatment) | 1150 mm 45.3 in |
| Dry weight | 700 kg (1543 lbs) |
| Final weight and dimensions will depend on completed specification | |

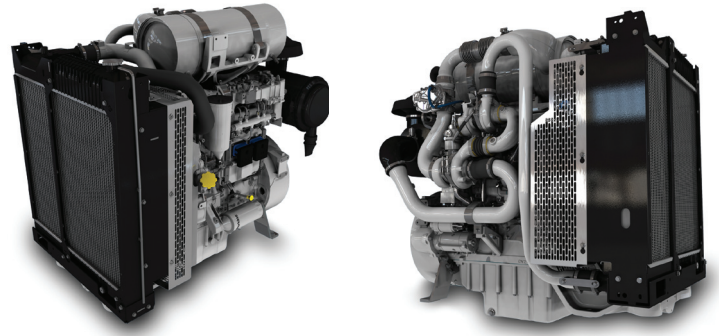

Emissions

Designed to meet 2011 EU Stage IIIB (Europe), EPA Tier 4 Interim (US) and MLIT Step 4 (Japan).

Dependable Power

World-class manufacturing capability and processes coupled with proven core engine designs assure reliability, quiet operation, and many hours of productive life.

Designed to be Productive

Series turbocharging with smart wastegate available on some ratings for fast response, high power, and increased torque.

Lifetime of Low Cost

Fuel consumption optimized to match operating cycles of a wide range of equipment and applications. No additional fluids or additives are required which lowers operating costs. Hydraulic tappets, multi-vee belts and 500 hour oil change intervals enable low-cost maintenance. Many service items have a choice of location on either side of the engine to enable maximum service access.

Industry Leading Flexibility

Exceptional power density enables standardisation across numerous applications. Multiple installation options minimise total package size. Ideal for equipment with narrow engine compartments.

Local Support, Global Coverage

- Perkins recognise that the customer relationship is important to machine manufacturers and we can offer a range of flexible solutions to help provide appropriate support, either to the OEM's network or directly to the machine customer.
- Perkins information systems enable our distributors to quickly diagnose engine faults and identify the right parts. The Perkins logistics operation is able to dispatch more than 45,000 different parts from stock, reaching the customer within 24 hours.
- Extended Service Contracts – protect and plan the cost of ownership.

1200 Series

1204E-E44TA/E44TTA

Industrial Open Power Unit

EU Stage IIIB, EPA Tier 4 Interim and MLIT Step 4 74.5-129.4 kW /100-173.5 hp

Engine Specification

Air Inlet

- Standard air cleaners

Control System

- Full electronic control system
- All connectors and wiring looms waterproof and designed to withstand harsh off-highway environments
- Flexible and configurable software features and J1939 standard communications I/O

Cooling System

- Engine mounted radiator with top tank temperature of 108°C
- 50:50 water glycol mix
- Detailed guidance on cooling system design and validation available to ensure machine reliability

Standard Emissions Control Equipment

- NRS - NOx Reduction System

Flywheels and Flywheel Housing

- Wide choice of drivetrain interfaces, SAE2 and SAE3 configurations

Fuel System

- Electronic high pressure common rail
- Standard and heavy duty fuel filtration

Oil System

- Choice of sumps for different applications

Power Take-off

- SAE A or SAE B flanges on left-hand side, additional SAE A flange available on front of the engine on some applications

General

- Balancer option available
- Pusher or puller fan options

1204E-E44TA

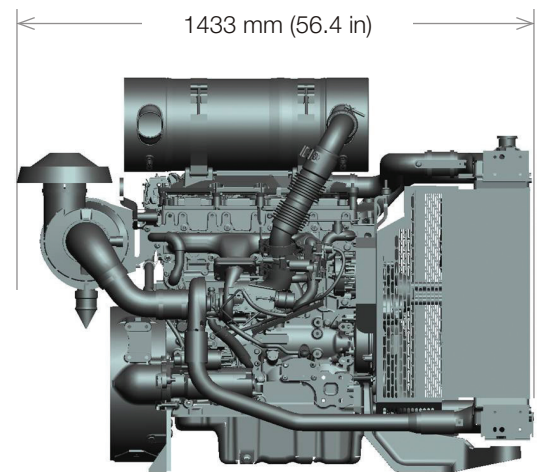
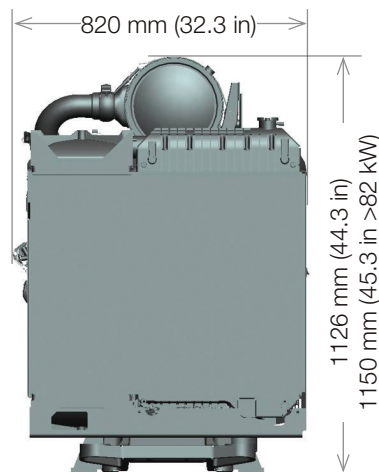

Final weight and dimensions will depend on completed specification

1204E-E44TTA

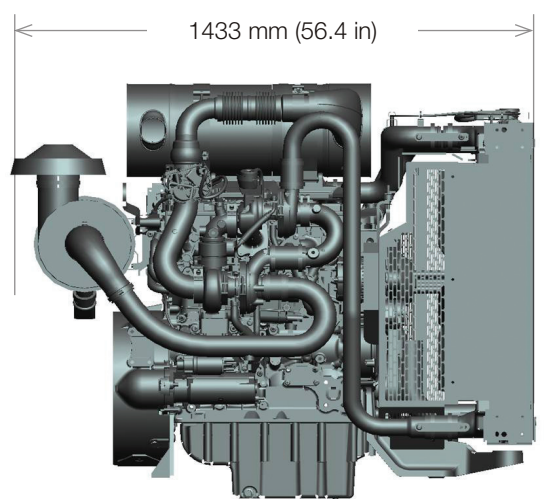
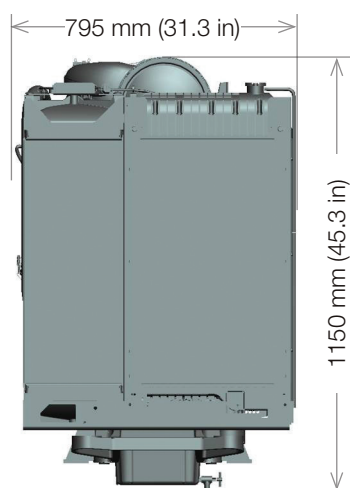

Final weight and dimensions will depend on completed specification

1200 Series - 1204E-E44TA/E44TTA

Industrial Open Power Unit

EU Stage IIIB, EPA Tier 4 Interim and MLIT Step 4 74.5-129.4 kW /100-173.5 hp

Performance Data

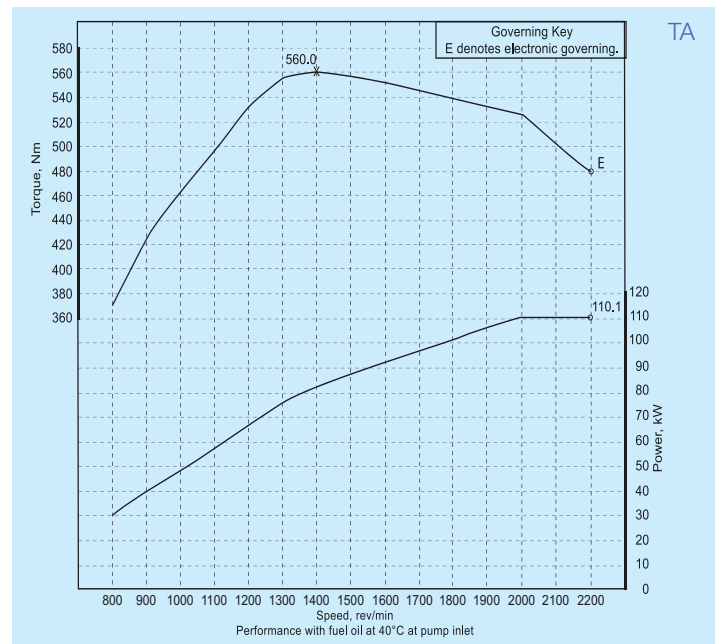
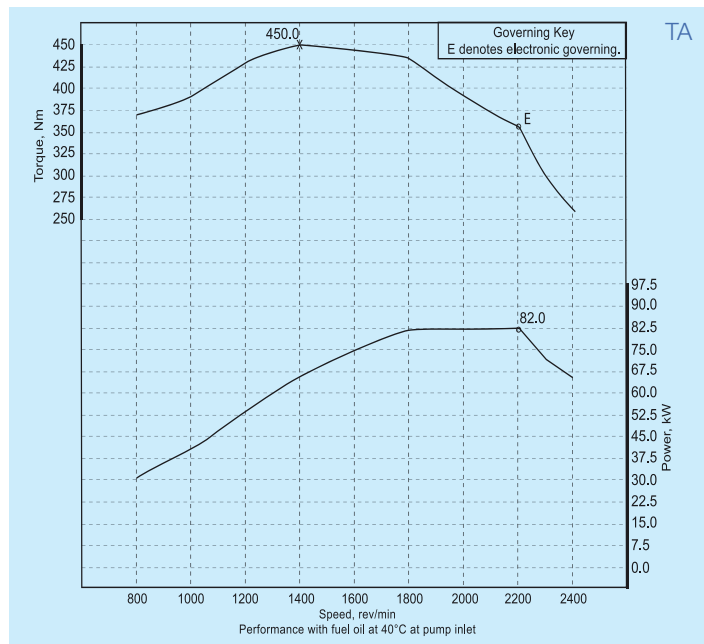

| Power kW (bhp) | Speed rev/min | Torque Nm | Speed rev/min | Rating Type |
|----------------|---------------|-----------|---------------|-------------|
| 74.5 (100.0) | 2200 | 450 | 1400 | B |
| *82.0 (110.0) | 2200 | 450 | 1400 | C |
| 92.5 (124.0) | 2200 | 530 | 1400 | B |
| 102.1 (137.0) | 2200 | 560 | 1400 | C |
| *110.1 (147.6) | 2200 | 560 | 1400 | C |
| 117.0 (157.0) | 2200 | 683 | 1400 | C |
| *129.4 (173.5) | 2200 | 750 | 1400 | C |

* Curve shown
Rating Standard ISO 14396:2002. Unless otherwise specified, all stated data is for maximum rated speed and 100% load.

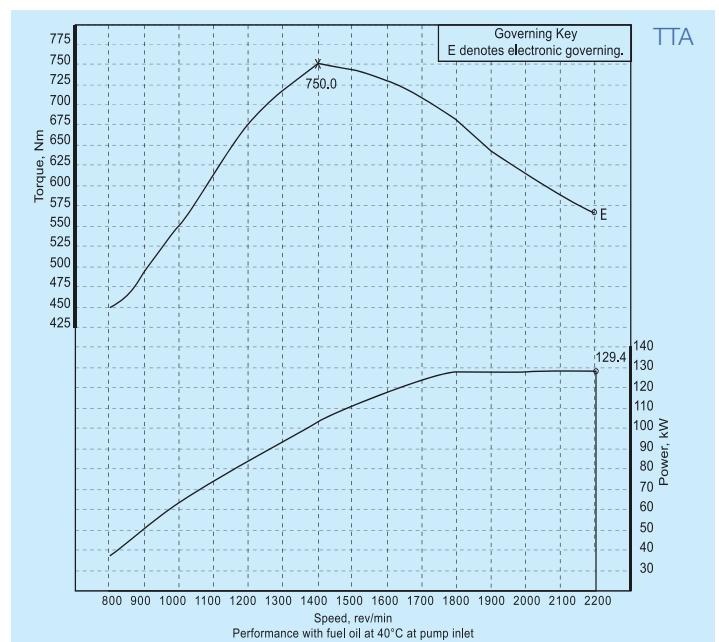

Rating Definitions and Conditions

IND-B for service where power and/or speed are cyclic (time at full load not to exceed 80%).

IND-C (Intermittent) is the horsepower and speed capability of the engine where maximum power and/or speed are cyclic (time at full load not to exceed 50%).

Additional ratings are available for specific customer requirements. Consult your Perkins distributor.

Photographs are for illustrative purposes only and may not reflect final specification.
All information in this document is substantially correct at time of printing and may be altered subsequently.
Publication No.PN1963/02/11 Produced in England ©2010 Perkins Engines Company Limited

Rating Conditions for Diesel Engines - up to 7.1 litres are based on ISO/TR14396, inlet air standard conditions with a total barometric pressure of 100 kPa (29.5 in. Hg), with a vapour pressure of 1 kPa (0.295 in Hg) and 25°C (77°F). Performance is measured using fuel to specification EPA 2D 89.330-96 with a density of 0.845-0.850 kg/L @ 15°C (59°F) and fuel inlet temperature 40°C (104°F).

1200 Series - 1204E-E44TA/E44TTA

Industrial Open Power Unit

EU Stage IIIB, EPA Tier 4 Interim and MLIT Step 4 74.5-129.4 kW /100-173.5 hp

Aftertreatment Configuration

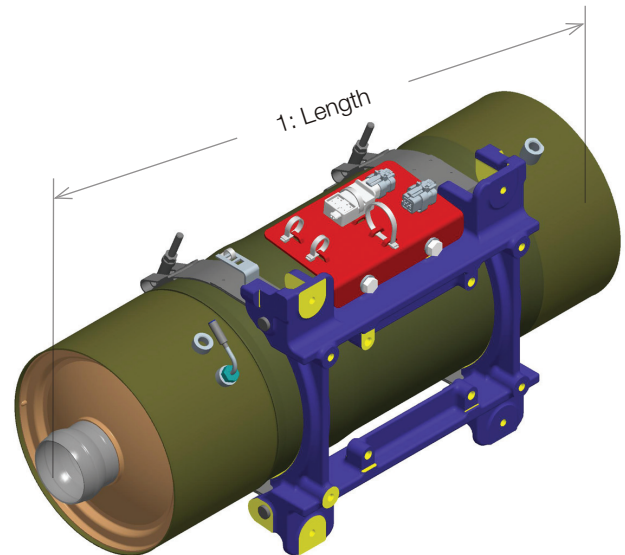
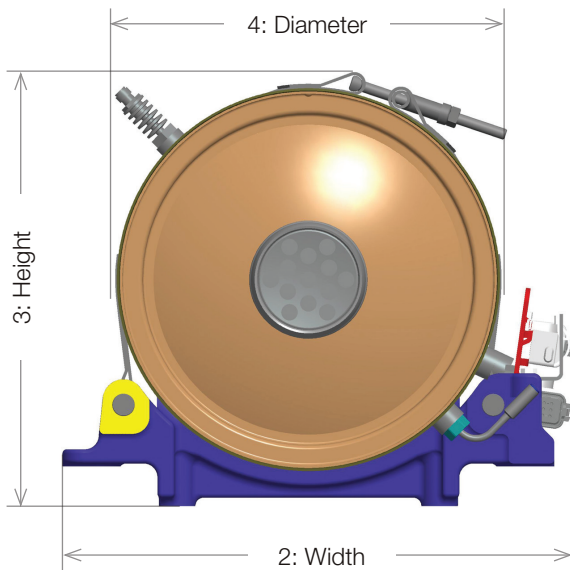

Technology

The DPF technology chosen is a wall flow filter configuration that performs through the whole work cycle of the engine thus allowing it to work efficiently.

Power

Using our advanced research and development techniques, we have perfectly matched the aftertreatment to the engine. The engine performance has then been optimised to give the maximum power and the regeneration is invisible to the operator.

Mounting

Remote and engine-mounted installation options provide OEM flexibility for many applications.

Service

Aftertreatment designed to be service-free (minimum 8,000 hours).

| | | ≤ 82 kW (110 hp) | > 82 kW (110 hp) |
|---|----------|--------------------|--------------------|
| 1 | Length | 802.5 mm (31.6 in) | 828 mm (32.6 in) |
| 2 | Width | 365 mm (14.3 in) | 365 mm (14.3 in) |
| 3 | Height | 279 mm (11 in) | 300.5 mm (11.8 in) |
| 4 | Diameter | 244.9 mm (9.6 in) | 270.3 mm (10.6 in) |
| | Weight | 34 kg (75 lbs) | 37 kg (81.6 lbs) |

Final weight and dimensions will depend on completed specification

Aftertreatment can be module shipped as separate part to be assembled by customer.

Aftertreatment

- DOC - Diesel Oxidation Catalyst
- DPF - Diesel Particulate Filter supplied, with a range of inlet and outlet options
- No ash service requirement, low temperature regeneration
- 3" flex pipe kits available with a variety of elbow options for turbocharger connection

Distributed by:

Perkins Engines Company Limited

Peterborough PE1 5NA
 United Kingdom
 Telephone +44 (0)1733 583000
 Fax +44 (0)1733 582240
www.perkins.com