

# 1200 Series 1206E-E70TTA

## Industrial Open Power Unit

EU Stage IIIB, EPA Tier 4 Interim and MLIT Step 4

151-205 kW / 202-275 hp

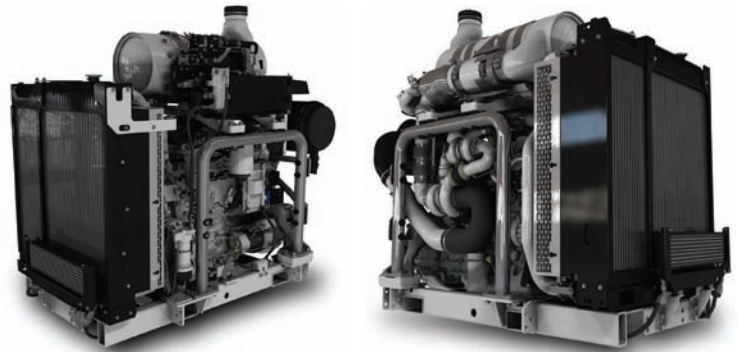

**Building on its already strong EU Stage IIIB and EPA Tier 4 industrial range, Perkins is pleased to announce the natural expansion of the 1200 Series to include the new Industrial Open Power Units (IOPUs).**

The new range of six cylinder IOPUs are an industry leader in flexibility, offering a wide choice of options to the customer.

The whole engine has been built around the demands of our customers and as such offers a great package with a simple integration design.

The 1206E-E70TTA IOPU has been given a boost in power. It is a series turbocharged, air-to-air charge cooled, 7 litre, 6 cylinder unit capable of producing 205 kW (275 hp).

The IOPUs are designed to be productive and have a new range of power ratings to ensure the customer maximizes their profitability.

Perkins have developed a reputation for designing and building reliable and durable engines suitable for the most demanding applications.

### Engine Data

Number of cylinders .....	6 vertical in-line
Bore and stroke .....	105 mm x 135 mm (4.13 in x 5.3 in)
Displacement .....	7.01 litres (427.7 in <sup>3</sup> )
Aspiration .....	Series turbocharged aftercooled
Cycle .....	4 stroke
Combustion system .....	Direct injection
Compression ratio .....	16.5:1
Rotation .....	Anti-clockwise, viewed on flywheel
Total lubricating capacity.....	13-16 litres (3.4-4.2 US gal)
Cooling system .....	Liquid
Total coolant capacity .....	15.2 litres (4 US gal)
Dimensions	
Length (inc air filter) .....	1902 mm (74.9 in)
Width .....	916 mm (36.0 in)
Height .....	1617 mm (63.7 in)
Dry weight .....	1200 kg (2645.5 lbs)
(includes aftertreatment)	

Final weight and dimensions will depend on completed specification

### Emissions

Designed to meet 2011 EU Stage IIIB (Europe), EPA Tier 4 Interim (US) and MLIT Step 4 (Japan).

### Dependable Power

World-class manufacturing capability and processes coupled with proven core engine designs assure reliability, quiet operation, and many hours of productive life.

### Designed to be Productive

Turbocharging with smart wastegate available on all ratings for fast response, high power, and increased torque.

### Lifetime of Low Cost

Fuel consumption optimized to match operating cycles of a wide range of equipment and applications. No additional fluids or additives are required which lowers operating costs. Hydraulic tappets, multi-vee belts, minimum 5000 hour diesel particulate filter ash service interval and 500-hour oil change intervals enable low-cost maintenance. Many service items have a choice of location on either side of the engine to enable choice of service access.

### Industry Leading Flexibility

Exceptional power density enables standardisation across numerous applications. Multiple installation options minimise total package size. Ideal for equipment with narrow engine compartments.

### Local Support, Global Coverage

- Perkins recognise that the customer relationship is important to machine manufacturers and we can offer a range of flexible solutions to help provide appropriate support, either to the OEM's network or directly to the machine customer.
- Perkins information systems enable our distributors to quickly diagnose engine faults and identify the right parts. The Perkins logistics operation is able to dispatch more than 45,000 different parts from stock, reaching the customer within 24 hours.
- Extended Service Contracts – protect and plan the cost of ownership.

# 1200 Series - 1206E-E70TTA

## Industrial Open Power Unit

EU Stage IIIB, EPA Tier 4 Interim and MLIT Step 4 151-205 kW / 202-275 hp

## Engine Specification

### Air Inlet

- Standard air cleaners

### Control System

- Full electronic control system
- All connectors and wiring looms waterproof and designed to withstand harsh off-highway environments
- Flexible and configurable software features and well supported SAE J1939 CAN bus enables highly integrated machines

### Cooling System

- Top tank temperature 108°C as standard to minimise cooling pack size
- 50:50 water glycol mix
- Detailed guidance on cooling system design and validation available to ensure machine reliability

### Standard Emissions Control Equipment

- NRS - NOx Reduction System

### Flywheels and Flywheel Housing

- Wide choice of drivetrain interfaces, SAE1, SAE2 and SAE3 configurations

### Fuel and Fuel System

- Electronic high pressure common rail
- Innovative filter design – ensures maximum protection of the engine

### Oil System

- Choice of sumps for different applications

### Power Take-off

- SAE A or SAE B flanges on left-hand side. Right hand side twin PTO also available. Engine power can also be taken from the front of the engine on some applications
- Factory fitted compressors are also available

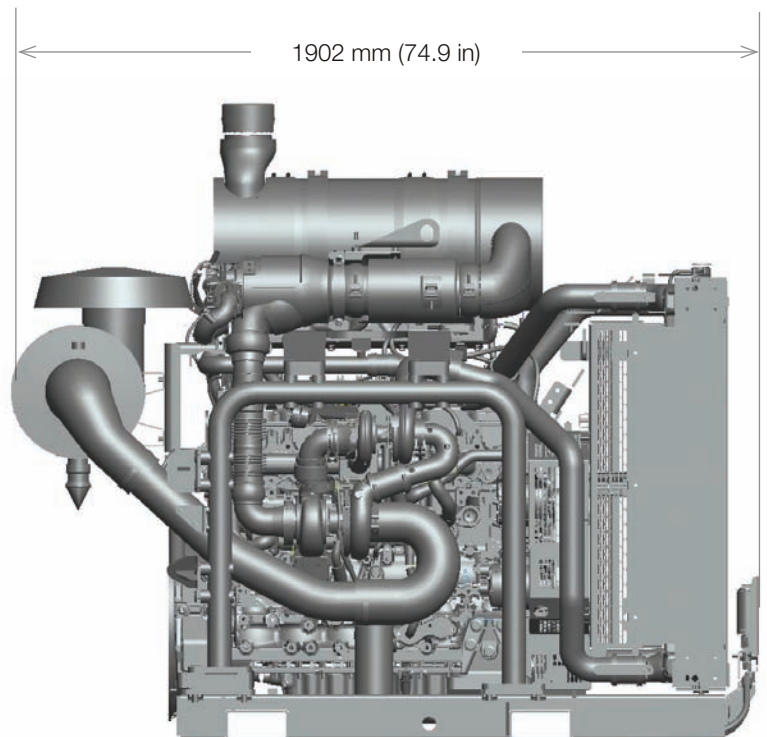
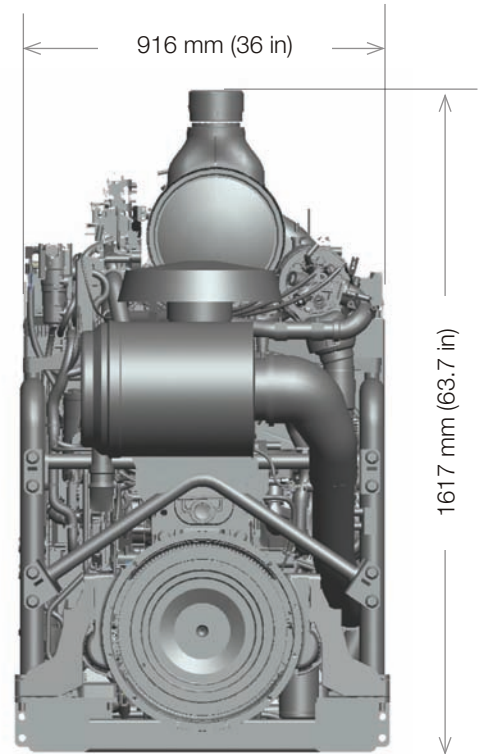

Final weight and dimensions will depend on completed specification

# 1200 Series - 1206E-E70TTA

## Industrial Open Power Unit

EU Stage IIIB, EPA Tier 4 Interim and MLIT Step 4 151-205 kW / 202-275 hp

## Performance Data

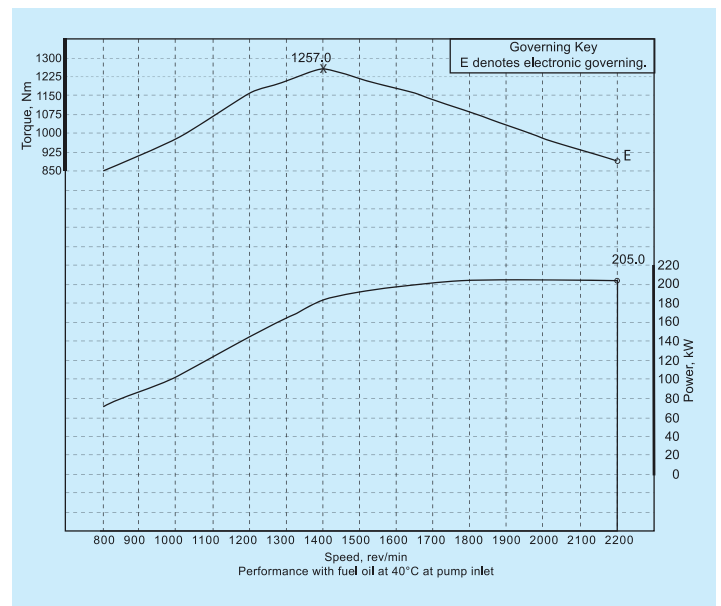
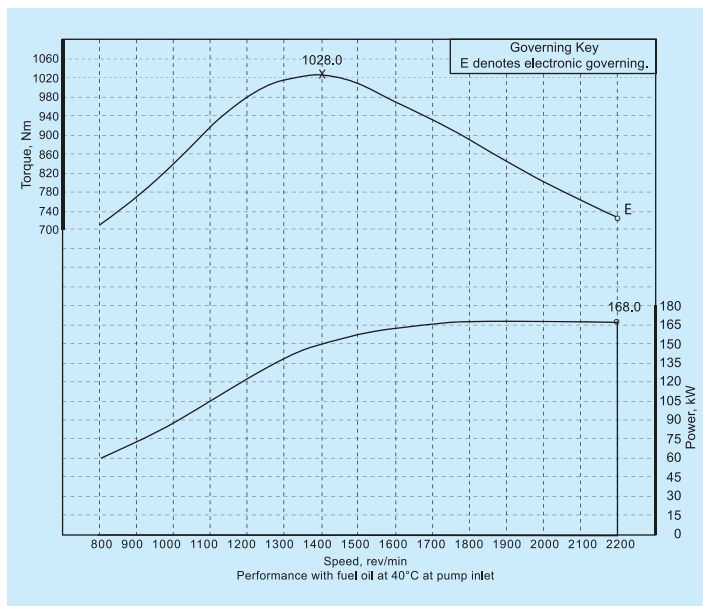

kW	Power (bhp)	Speed (rev/min)	Torque (Nm)	Speed (rev/min)	Rating Type
151.0	(202.5)	2200	922	1400	B
*168.0	(225.3)	2200	1028	1400	B
*186.5	(250.1)	2200	1142	1400	C
*205.0	(274.9)	2200	1257	1400	C

\*Curve shown  
Rating Standard ISO 14396:2002  
Unless otherwise specified, all stated data is for maximum rated speed and 100% load.

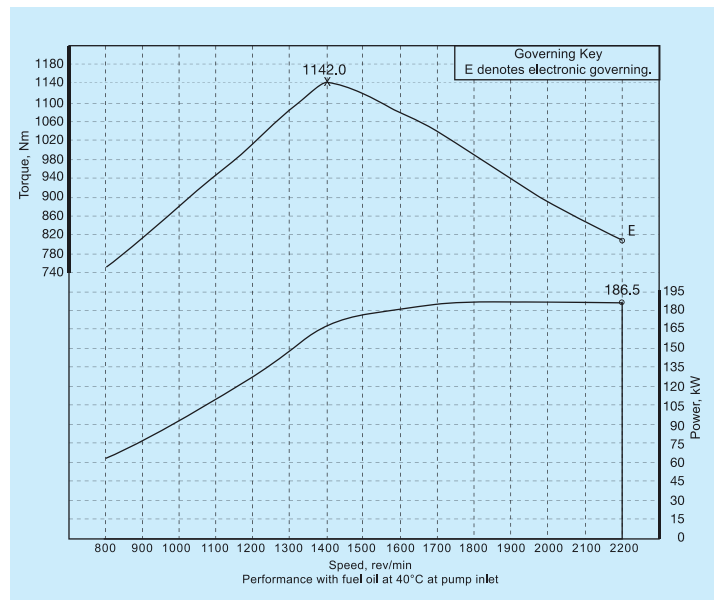

### Rating Definitions and Conditions

**IND-B** for service where power and/or speed are cyclic (time at full load not to exceed 80%).

**IND-C (Intermittent)** is the horsepower and speed capability of the engine where maximum power and/or speed are cyclic (time at full load not to exceed 50%).

**IND-D** for service where maximum power is required for periodic overloads (time at full load not to exceed 10% of the duty cycle).

Additional ratings are available for specific customer requirements. Consult your Perkins distributor.

**Rating Conditions for Diesel Engines** - up to 7.1 litres are based on ISO/TR14396, inlet air standard conditions with a total barometric pressure of 100 kPa (29.5 in. Hg), with a vapour pressure of 1 kPa (0.295 in Hg) and 25°C (77°F). Performance is measured using fuel to specification EPA 2D 89.330-96 with a density of 0.845-0.850 kg/L @ 15°C (59°F) and fuel inlet temperature 40°C (104°F).

# 1200 Series - 1206E-E70TTA

## Industrial Open Power Unit

EU Stage IIIB, EPA Tier 4 Interim and MLIT Step 4 151-205 kW / 202-275 hp

## Aftertreatment Configuration

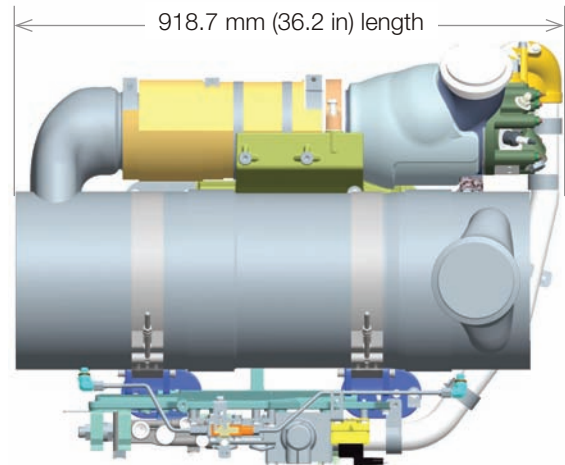
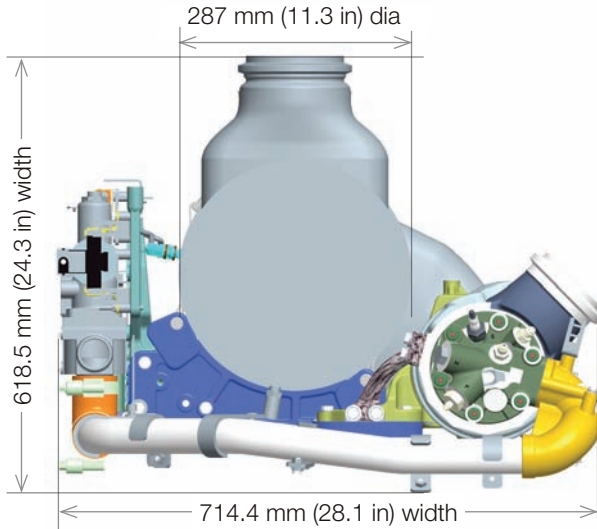

### Technology

The DPF technology chosen is a wall flow filter configuration that performs through the whole work cycle of the engine thus allowing it to work efficiently.

### Power

Using our advanced research and development techniques, we have perfectly matched the aftertreatment to the engine. The engine performance has then been optimised to give the maximum power and the regeneration is invisible to the operator.

### Flexibility

Flexible regeneration options maximise uptime.

### Regeneration

High Temperature Regenerations System maximises fuel efficiency during regeneration.

### Mounting

Frame or remote installation options provide OEM flexibility for many applications.

### Service

5,000 hour DPF ash service interval.  
Available in 12 or 24 volt systems.

	≤172 kW	≥172 kW
1 Length	918.7 mm (36.2 in)	918.7 mm (36.2 in)
2 Width	714.4 mm (28.1 in)	714.4 mm (28.1 in)
3 Height	618.5 mm (24.3 in)	643.9 mm (25.3 in)
4 Diameter	287 mm (11.3 in)	337.8 mm (13.3 in)
Weight	124 kg (273.4 lbs)	134 kg (295.4 lbs)

Final weight and dimensions will depend on completed specification

Remote aftertreatment module shipped as separate part to be assembled by customer.

### Aftertreatment

- CEM - Clean Emissions Module
- High Temperature Regeneration System
- DOC - Diesel Oxidation Catalyst
- DPF - Diesel Particulate Filter and regeneration system supplied, with a range of inlet and outlet options
- 3" flex pipe connection kit with rotatable elbow for 60° and 90° RS inlet flexibility

### Perkins Engines Company Limited

Peterborough PE1 5NA  
United Kingdom  
Telephone +44 (0)1733 583000  
Fax +44 (0)1733 582240  
[www.perkins.com](http://www.perkins.com)

Distributed by: